

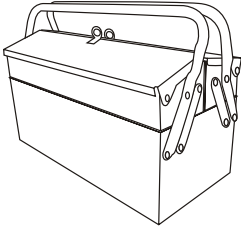

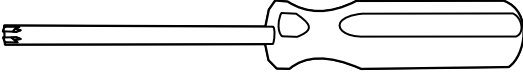
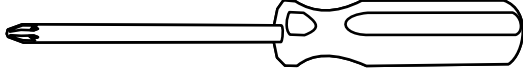

Re-position kit for main PCB

Vertical home ventilation units

Rev. 1.1

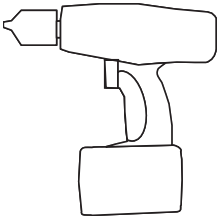
Required tools

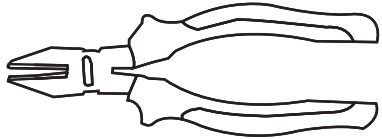
	1 x TX-10 
	1 x PZ-2 
	1 x 3 mm 
	1 x 
	1 x 3 mm 
	1 x 

Important!

- Only trained and certified personnel is allowed to replace parts
- Turn off all power to the unit before starting the work
- Make sure that all work has been carried out before the power is switched back on
- Be sure to observe ESD measures to avoid damaging the PCB due to static electricity

Remove front

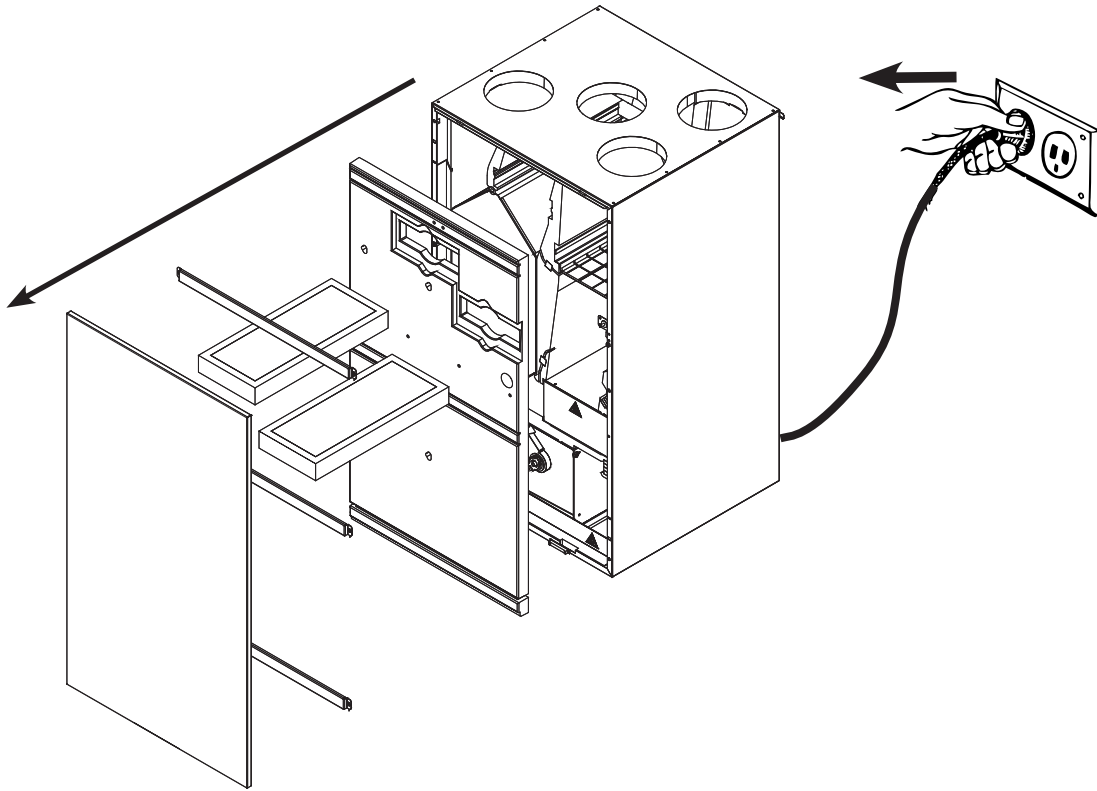

Remove existing PCB

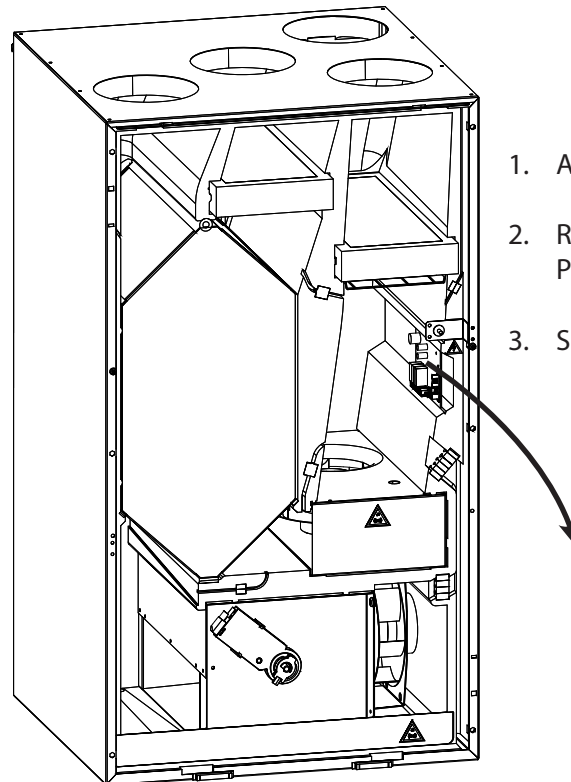

1. Assure that power is disconnected.
2. Remove all plugs connected to the PCB board including the earth wire
3. Slide existing PCB board out

Remove sensor wire harness assembly

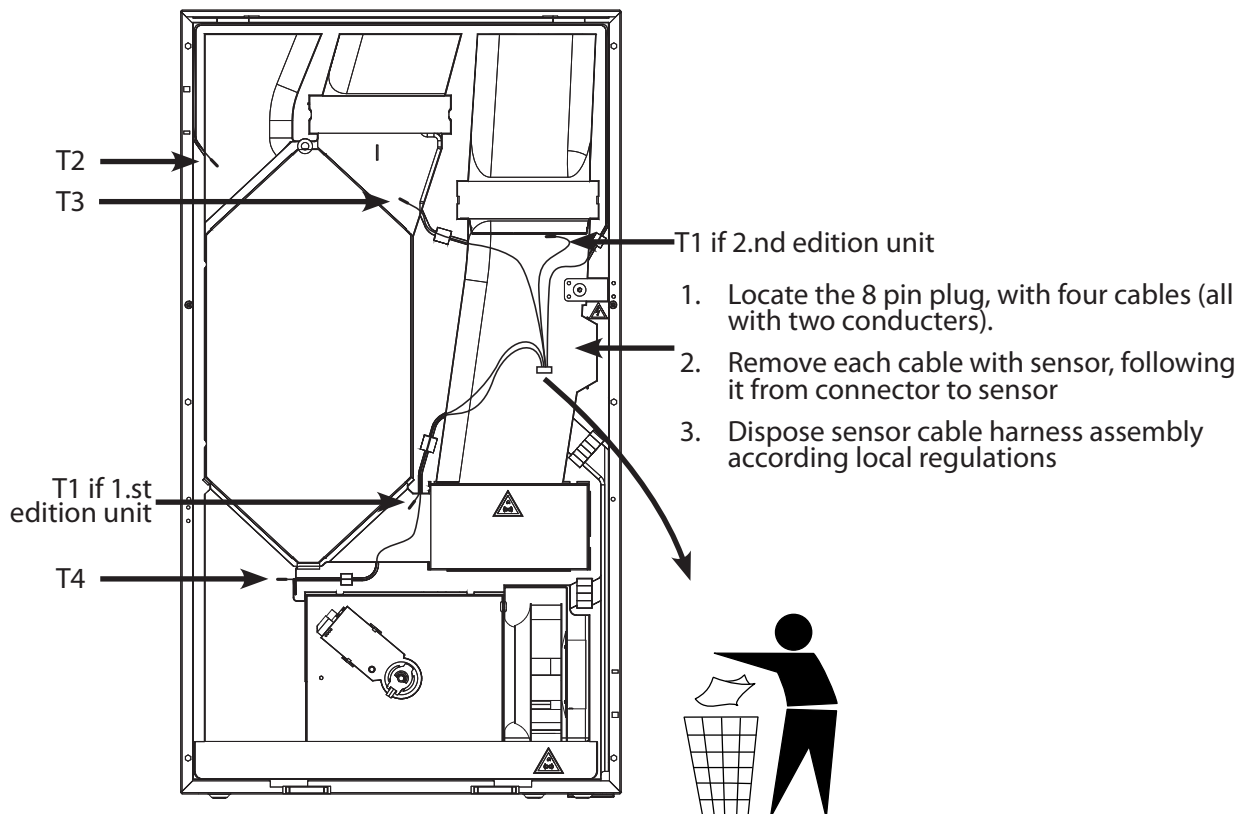

Overview, new PCB position

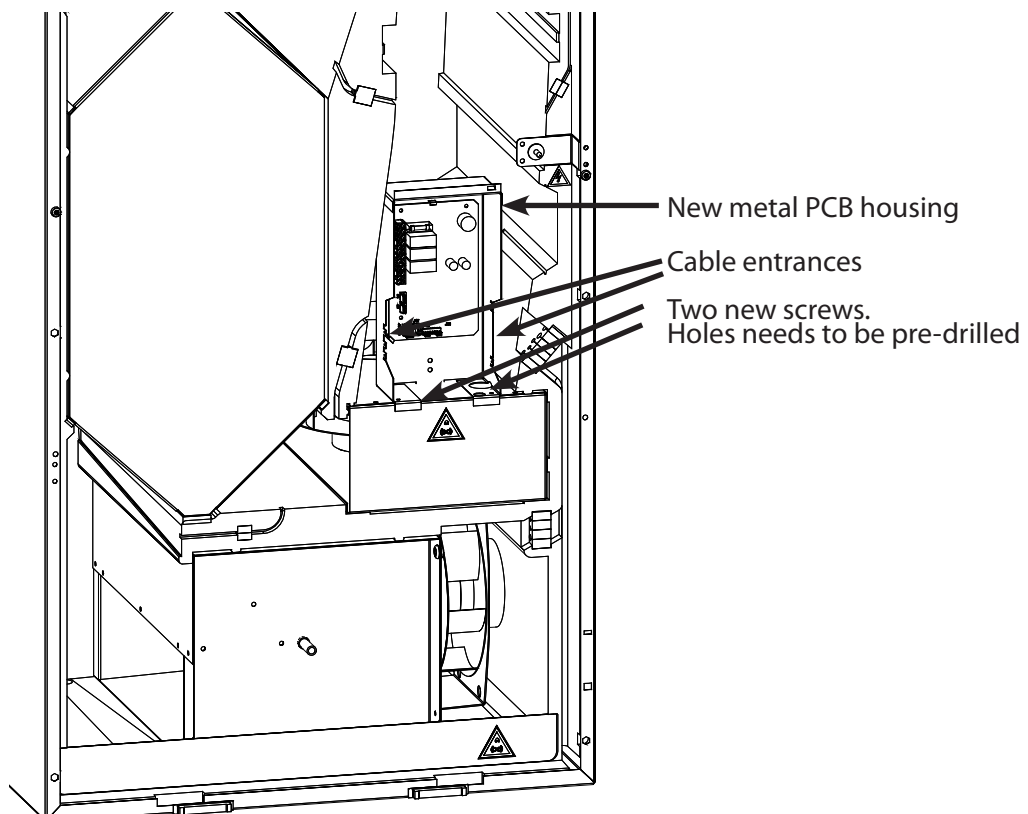

Pre-drill holes

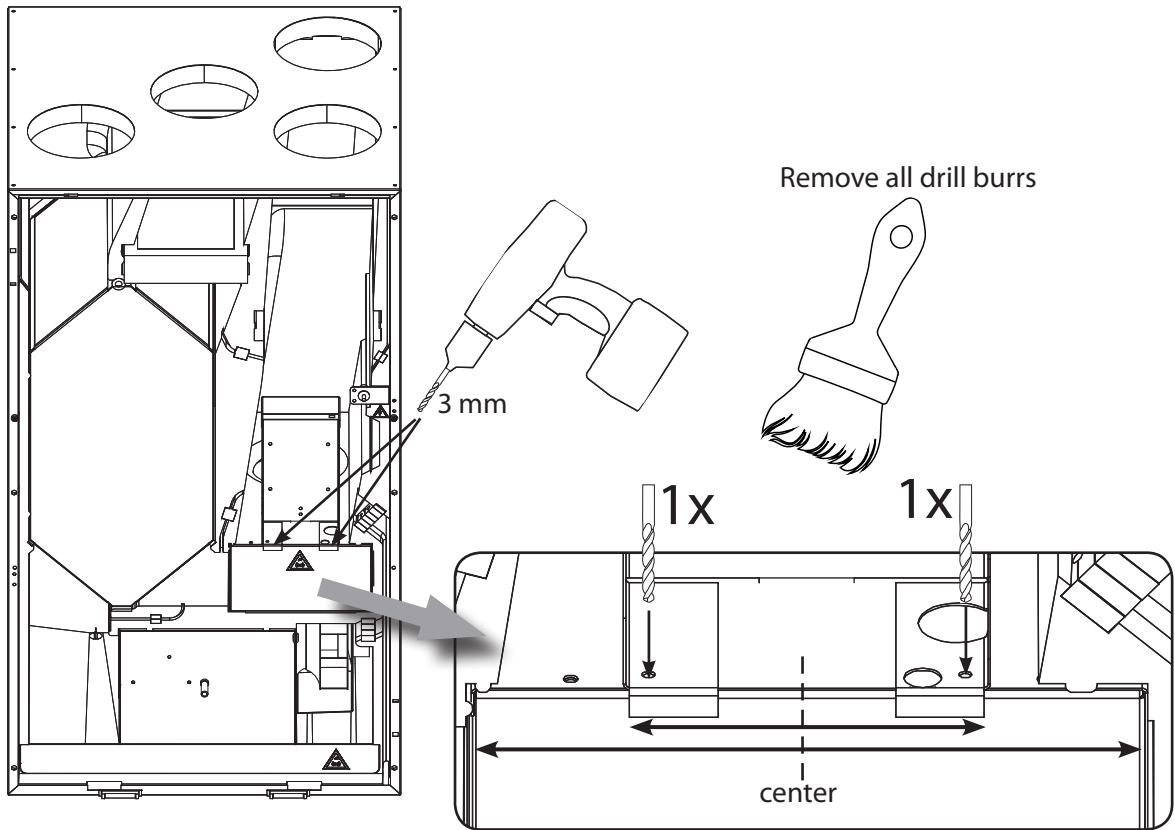

Mount and secure PCB box

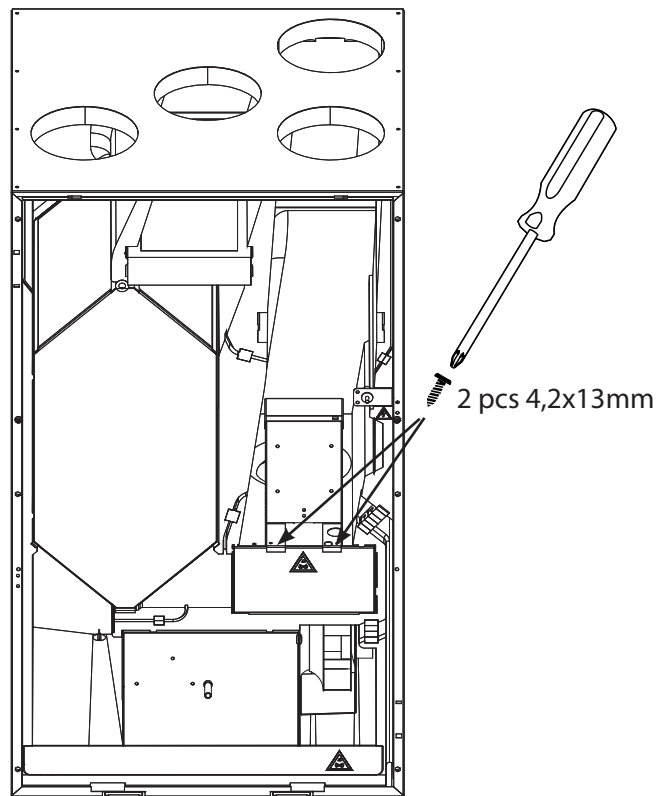

Mount PCB holders

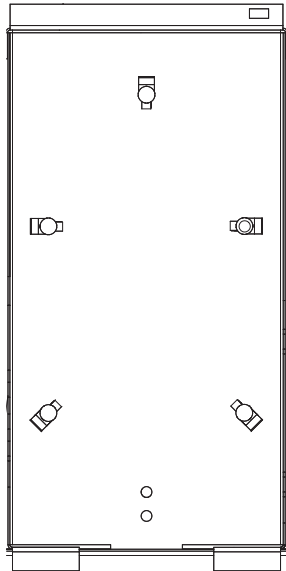

Mount the five PCB holders inside the new metal housing. Openings facing in the directions shown

Mount PCB

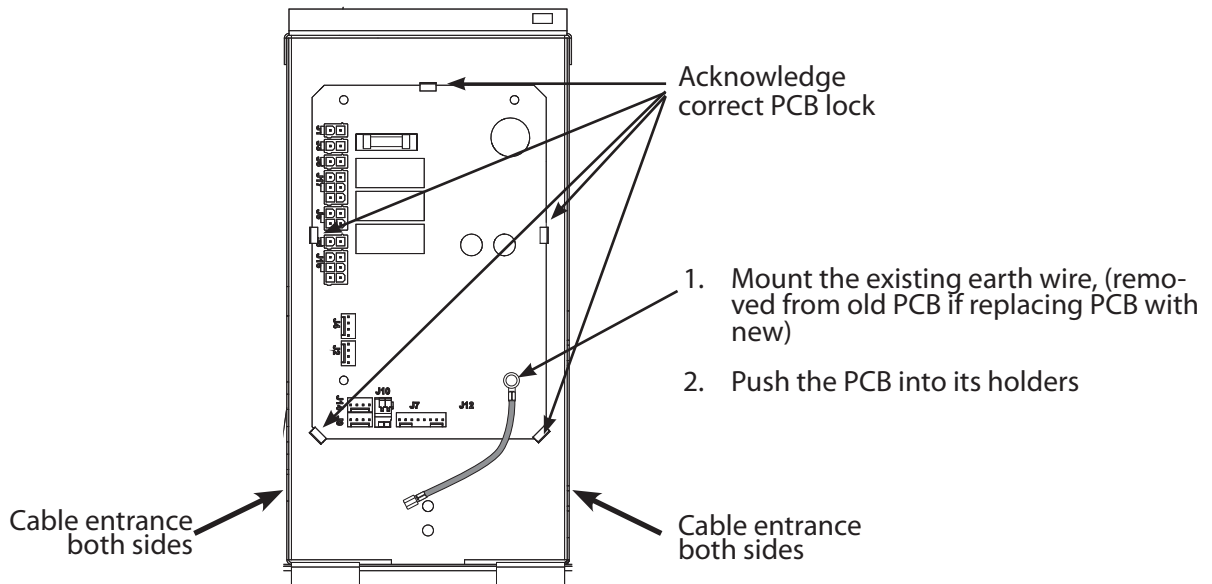

Mount earth wires

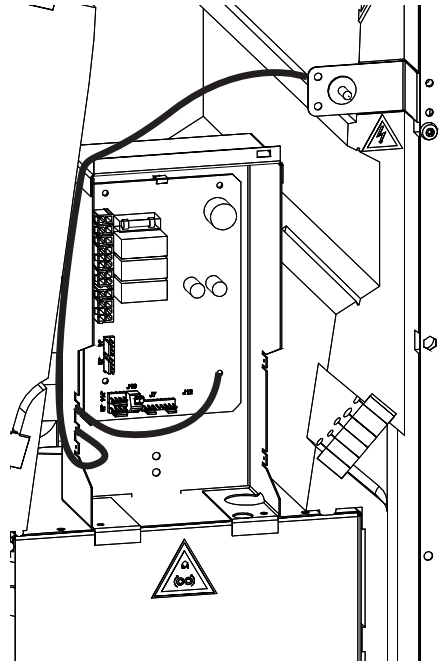

1. Mount the existing earth wire to the PCB box metal
2. Mount the new supplied earth cable from PCB box left side to filter reset switch bracket

Locate components

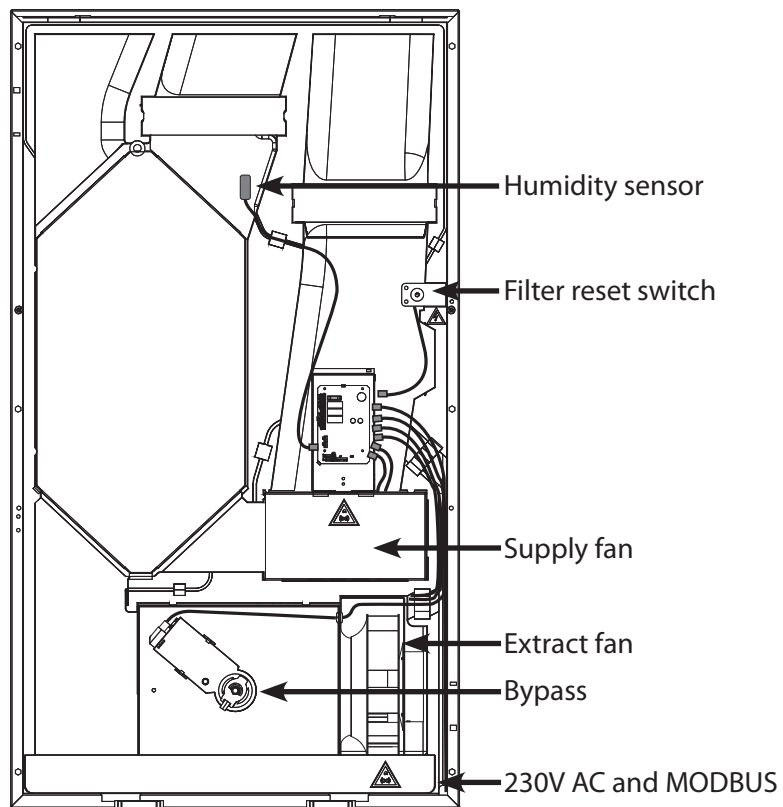

Connect existing cables to PCB

Route all cables into the new PCB covers lower sides, right or left, and connect

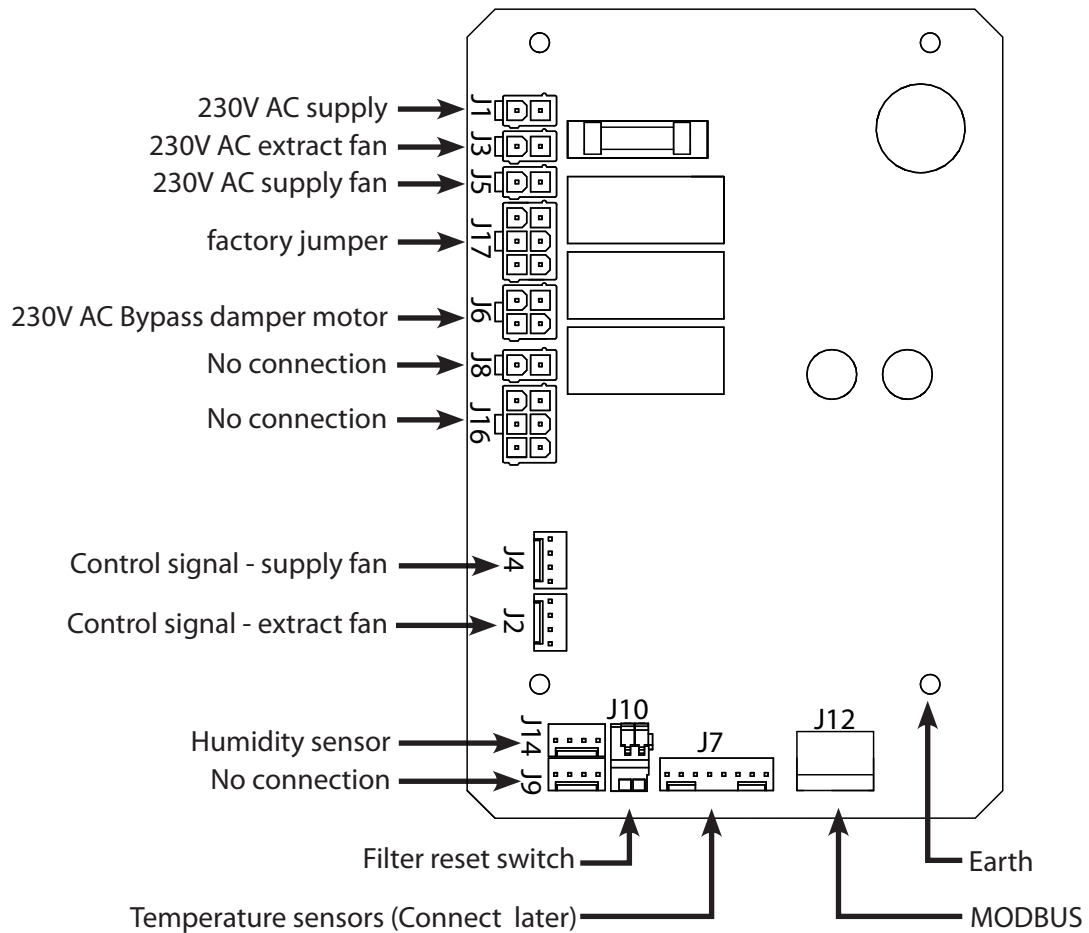

New sensor wire harness assembly

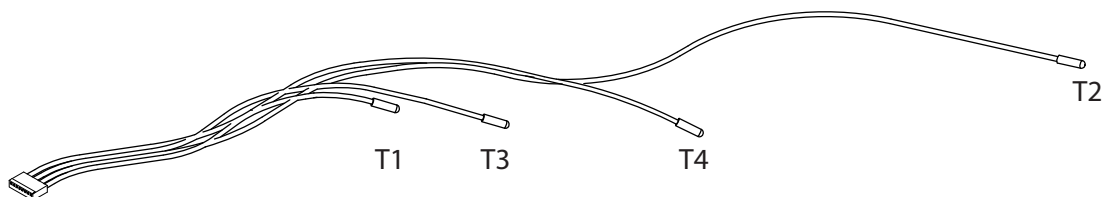

Place sensor cables

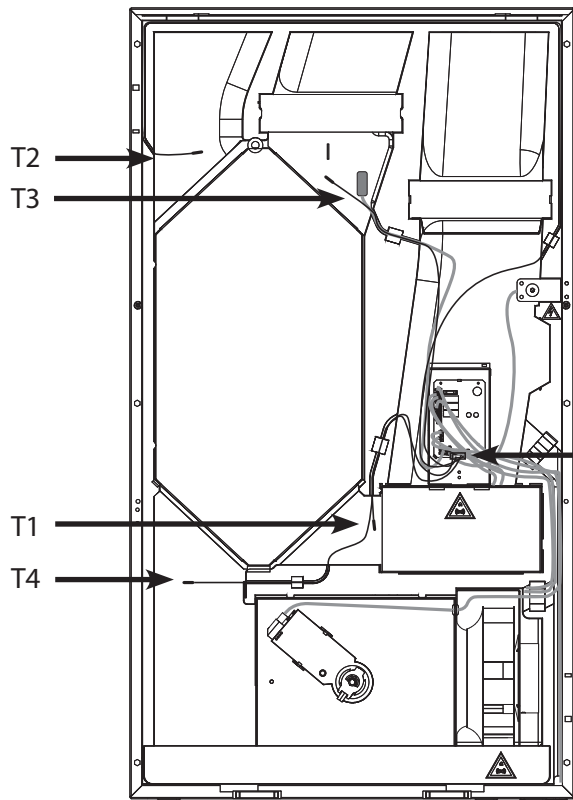

1. Connect new sensor plug to PCB (J7)
2. Route and fasten each sensor cable, one by one, according to the previous illustration

Secure T1 sensor



Secure T2 sensor

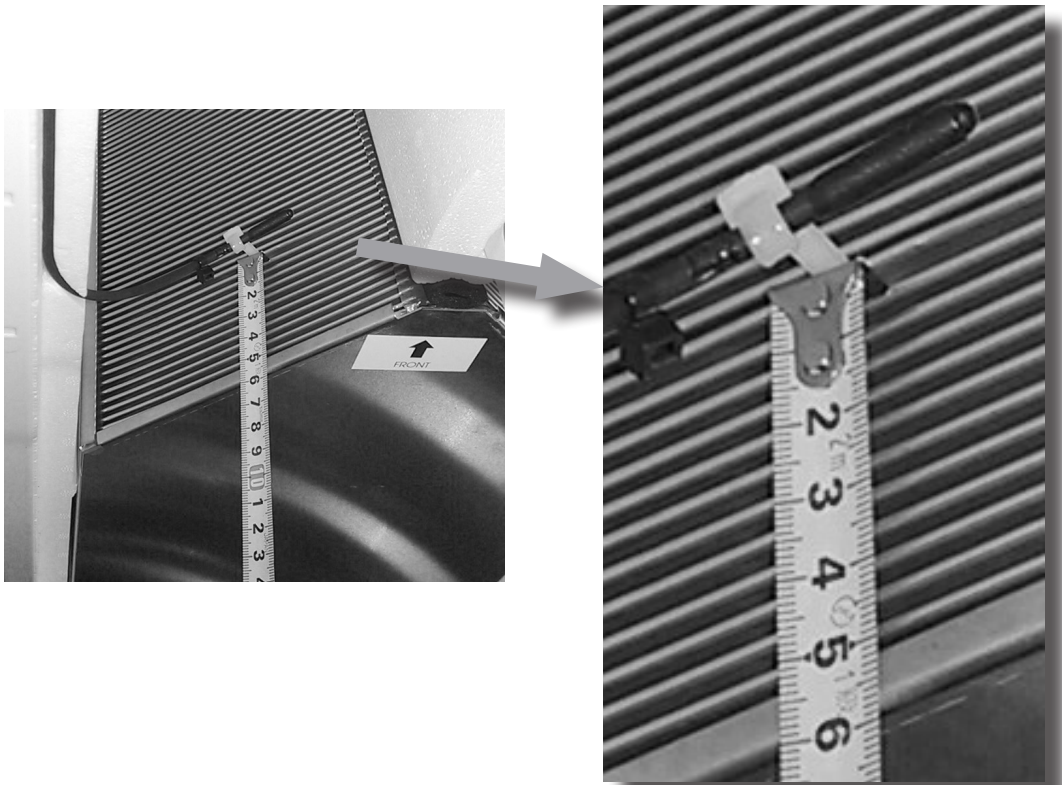

Secure T3 and Humidity sensor

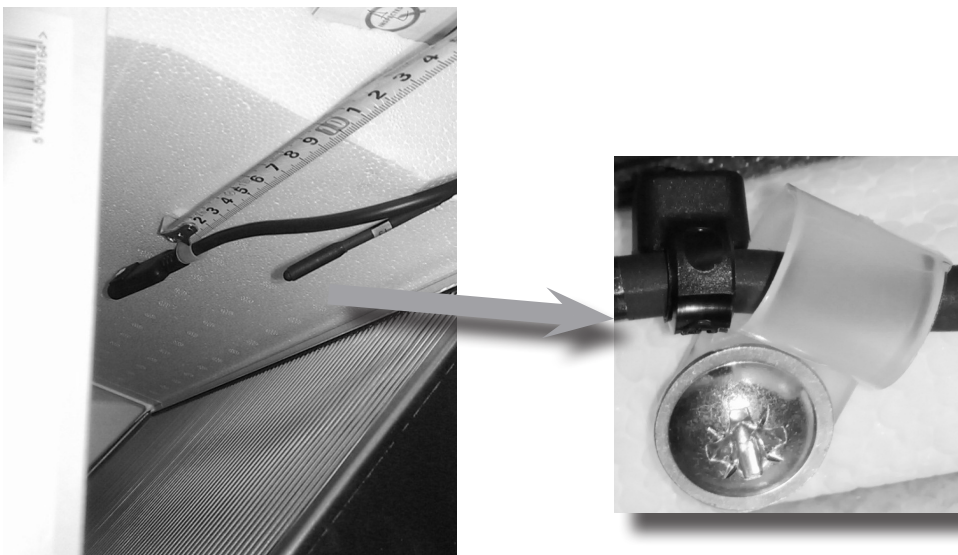

Secure T4 sensor

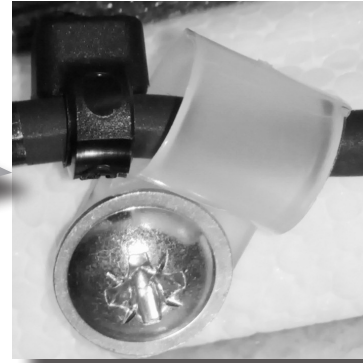

Finalizing

1: arrange and secure cables

Smaller size units, surplus cable in front of PCB

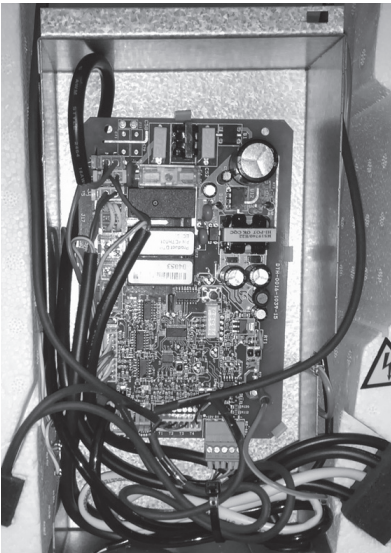

Larger size units, surplus cable hidden behind box

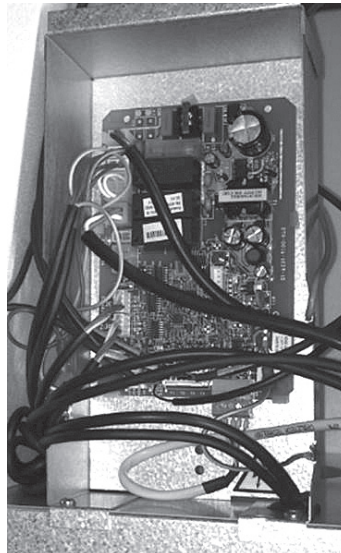

2: re-mount front cover

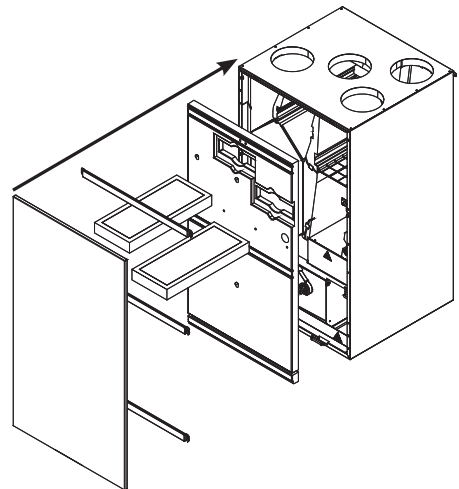



081151 - Rev1.1